

## 12 HS07-1624, HS11-1624 ASSEMBLY

### WARNING

This diagram is for your reference only. Do not attempt to service or repair the Tool.  
Do not take the Tool apart. Contact an authorized Nitto dealer for all service and repair of the Tool.  
Improper service and repair can cause accidents and severe injuries.  
Never attempt to modify the Tool.  
Never attempt service or repair the Tool yourself.

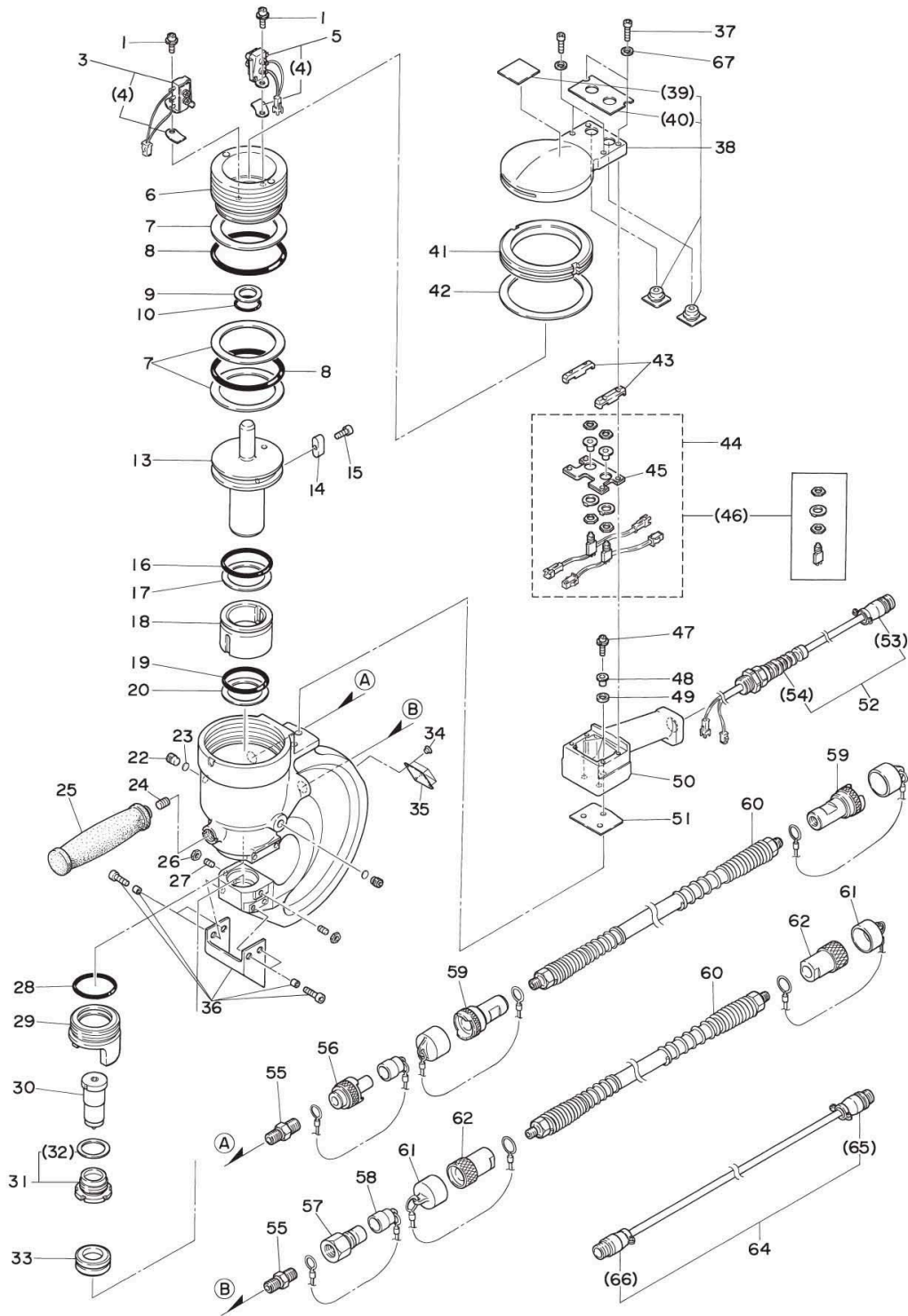

## 13 HS07-1624, HS11-1624 PARTS LIST

The part numbers with ( ) are included in the Ass'y parts written above them.

No.	Parts No.	Parts Name	Q'ty	Price
1	TQ03336	Hex. Socket Head Cap Screw with spring washer 6 × 12	2	
3	TB02278	Limit Switch Lower End Ass'y	1set	
4	(TQ02047) (TQ02048)	Shim 1.0 (for Adjustment) Shim 0.5 (for Adjustment)		
5	TB02277	Limit Switch Upper End Ass'y	1set	
6	TQ02014	Cap	1	
7	TQ02015	Back-up Ring P-85 T3	3	
8	TQ02011	O-Ring P-85 PUR	2	
9	CP23977	Back-up Ring P-20 T2	1	
10	TQ02016	O-Ring P-20	1	
13	TQ02005	Ram	1	
14	TQ02006	Parallel Key 10 × 8 × 22	1	
15	TP06342	Hex. Socket Head Cap Screw 4 × 10	1	
16	TQ02002	O-Ring P-60 PUR	1	
17	TQ02003	Back-up Ring P-60 T2	1	
18	TQ01999	Bushing	1	
19	TQ02000	O-Ring P-45 PUR	1	
20	TQ02001	Back-up Ring P-45 T2	1	
22	TQ02054	Set Screw	2	
23	TQ02055	Copper Packing 10 × 15	2	
24	TQ02004	Hex. Socket Set Screw with Dog Point 8 × 16	1	
26	TQ01050	Small Hex. Nut M8	2	
27	TQ02304	Hex. Socket Set Screw with Cone Point 8 × 20	2	
28	CP28124	O-Ring P-45	1	
29	TQ02043	Stripper	1	
30	TJ06676	D Punch 22	1	
31	TA99036	Lock Nut Ass'y	1set	
32	(TP07009)	Urethane Washer 31 × 40 × 3.1	1	
33	TJ06677	D Die 22	1	
34	TP05136	Drive Rivet NO.2 × 4.8	4	
35	TQ03224	Plate Model Number (HS07-1624)	1	
	TQ03226	Plate Model Number (HS11-1624)	1	
37	TP04154	Hex. Socket Head Cap Screw 4 × 16	4	
67	TQ12338	Washer M4	4	
38	TB02463	Head Cover Ass'y	1set	
39	(TQ03223)	Label Warning	1	
40	(TQ03222)	Label Switch	1	
41	TQ02027	Lock Ring	1	
42	TQ02197	Folding washer	1	
43	TQ02051	Spacer	2	
44	TB02387	Switch Plate Ass'y	1set	
45	(TB01924)	Switch Plate Sub Ass'y	1set	

No.	Parts No.	Parts Name	Q'ty	Price
46	(TQ06476)	Push Switch MB2011 L/B	2	
47	TQ03338	Hex. Socket Head Cap Screw with spring washer 6 × 18	3	
48	TQ02044	Distance Collar M6	3	
49	TQ02045	Washer 10 × 18 × 2	3	
50	TQ02038	Grip	1	
51	TQ02046	Grip Sheet	1	
52	TB02389	Metal Concent Cord Ass'y	1set	
53	(TQ02036)	Metal Consent Relay Plug SRCN1A13-5P	1	
54	(TQ02219)	Cord Stopper BS-9	1	
55	TQ02142	Nipple R3/8 × R3/8	2	
56	CA94119	700R-3P Cap Ass'y	1set	
57	CA82240	450B-3P Ass'y	1set	
58	CB09421	450B-3P-D Ass'y	1set	

### Accessories

No.	Parts No.	Parts Name	Q'ty	Price
25	TA92089	Sub Handle Ass'y	1set	
36	TB02230	Chip Guard Ass'y	1set	
59	CA94118	700R-3S Cap Ass'y	2sets	
60	TP05184	Ultra-high Pressure Hose	2	
61	CA96464	3S Cap Ass'y	2sets	
62	CB00126	450B-3S All Ass'y	2sets	
64	TB02390	Switch Cord Ass'y	1set	
65	(TQ02568)	Metal Concent Straight Plug SRCN6A13-5P	1	
66	(TQ02567)	Metal Concent Straight Plug SRCN6A13-5S	1	
	TP01939	Hex. Socket Screw Key 4	1	
	TP04004	Hex. Socket Screw Key 5	1	
	TP06012	Spanner	1	
	TP17991	Spanner 12	1	
	TQ07167	Tool Box	1	
	TQ03228	Instruction Manual	1	