

HA06-1322



MODEL

# HA06-1322

HA06-1322

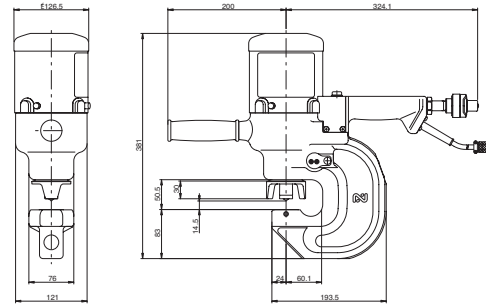

### Specifications

Model		HA06-1322	
Max. Throat Depth	inch (mm)	2-3/8" (60)	
Punching Capacity (for Mild Steel)	Max. Punching Diameter	inch (mm)	7/8" (22)
	Max. Punching Thickness	inch (mm)	1/2" (13)
Hole Making Time	sec	Punching Time 10.5	
Allowable Max. pressure	psi (kg/cm <sup>2</sup> )	10,000 psi (700)	
Max. Output	lbf (tf)	68,355 (34)	
Ram Stroke	inch (mm)	53/64" (21)	
Mass (Weight)	lbs (kg)	47 (21.5)	

### Standard Accessories for HA06-1322

- Hose cord assembly
- 22 mm "D" series punch & die
- Sub handle assembly
- Spanner wrench
- 4 mm Allen wrench
- Tool box