

INSTRUCTION MANUAL

Professional tool SCREW FASTENING MONITOR

delvo

Model: DTM10/DTM45

Parts List

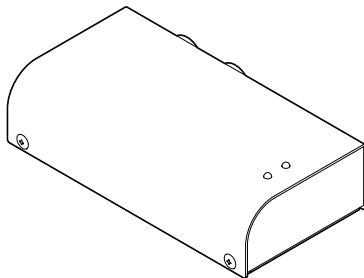

EN

This document is for the special repair operator.

General users should never disassemble the product.

When repair of the tool or part replacement becomes necessary, contact the retailer where you purchased the tool.

Le présent document est destiné aux techniciens de réparation spécialisés.

FR

Les utilisateurs généraux ne doivent jamais démonter le produit.

Lorsqu'une réparation ou le remplacement de pièces est nécessaire, contactez le revendeur auprès duquel vous avez acheté l'outil.

DE

Dieses Dokument gilt für speziell ausgebildete Wartungstechniker.

Allgemeine Nutzer dürfen das Produkt niemals zerlegen.

Wenn das Werkzeug repariert oder ein Teil ausgetauscht werden muss, wenden Sie sich an den Händler, von dem Sie das Werkzeug erworben haben.

IT

Questo documento è destinato all'operatore addetto alle riparazioni speciali.

Gli utenti generici non devono mai tentare di smontare il prodotto.

Per la riparazione dell'utensile o qualora si renda necessaria la sostituzione di un pezzo, rivolgersi al rivenditore presso il quale è stato acquistato l'utensile.

ES

Este documento es para el operador de reparaciones especiales.

Los usuarios generales no deberán desmontar jamás el producto.

Para la reparación de la herramienta o si resulta necesaria la sustitución de piezas, póngase en contacto con el vendedor del que adquirió la herramienta.

PT

Este documento destina-se ao operador de reparações específico.

Os utilizadores gerais não devem nunca desmontar o produto.

Se for necessário substituir alguma peça ou reparar a ferramenta, entre em contacto com o revendedor onde adquiriu a ferramenta.

SC

本文档专为特约维修操作人员准备。

一般用户严禁拆解产品。

需要维修工具或更换零件时，请联系购买工具的零售商。

JP

本書は、専門修理業者向けの資料です。

一般ユーザーの方は、絶対に製品を分解しないでください。

工具の修理や部品の交換が必要な場合は、お買い求めの販売店にお問い合わせください。

● Please read manual carefully before you attempt to use your tool so that you may use it properly and safely.

• Due to continuous product development/improvement the specifications and configurations in this document are subject to change without prior notice.

Manufactured by.

NITTO KOHKI CO., LTD.

9-4, Nakaikegami 2-chome, Ohta-ku, Tokyo, 146-8555, Japan

Tel : +81-3-3755-1111 Fax : +81-3-3753-8791

(Original Instructions)

TV08156-0 11/2019

EXPLODED VIEW (DTM10/DTM45)

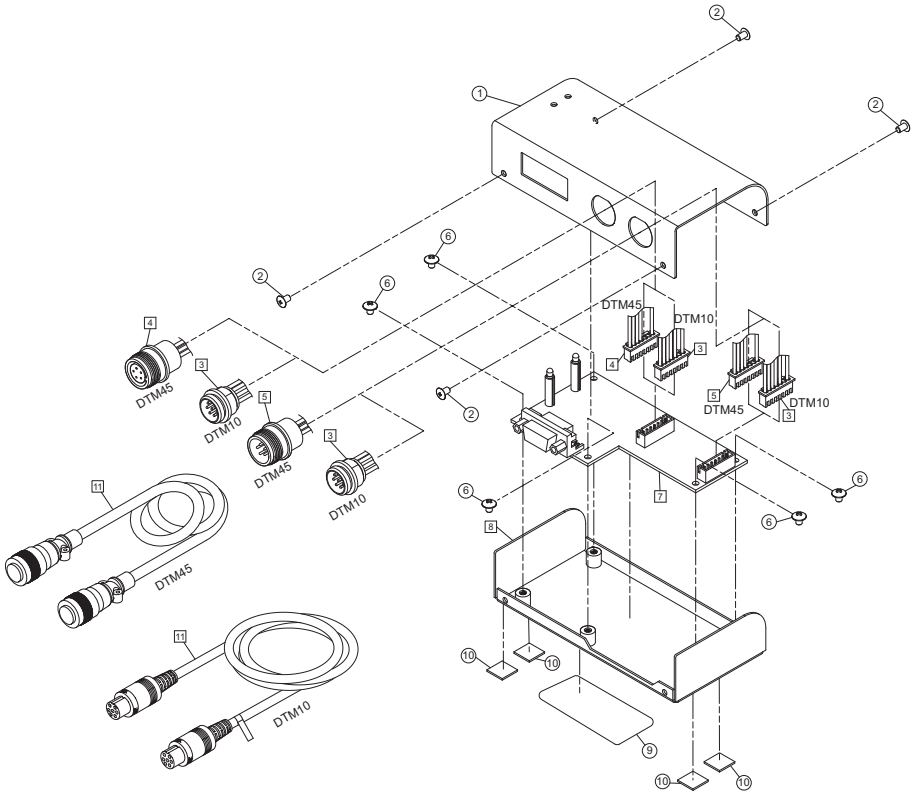

PARTS LIST (DTM10/DTM45)

No.	Parts Name	Parts No.	Q'ty
1	Cover (DTM10)	TV08146	1
	Cover (DTM45)	TV08200	1
2	Low Head Screw 3×5	TV08149	4
3	Receptacle Assembly (DTM10)	TD08727	2
4	Receptacle A Assembly (DTM45)	TD09724	1
5	Receptacle B Assembly (DTM45)	TD09725	1
6	Screw 3×6	TV04112	5
7	Control Base Assembly (DTM10)	TD09716	1
	Control Base Assembly (DTM45)	TD09717	1
8	Chassis Assembly	TD09723	1
9	Rating Plate		1
10	Rubber Foot	TV08152	4
11	Connection Cord Assembly (DTM10)	TD09144	1
	Connection Cord Assembly (DTM45)	TD09555	1